

Wireless Motion Sensor

Plantweb Insight™ Connected Lighting Application
Compatible with Mercmaster™ Connect LED Luminaires

NEC/CEC: Class I, Division 1, Groups A, B, C, D | Class I, Zone 0 AEx ia IIC | Ex ia IIC | Type 3R, 4, 4X | IP66 | Suitable for Use in Wet Locations
ATEX/IECEX: Zone 0

Applications

- Intrinsically safe and battery powered WirelessHART motion Sensor suitable for use in:
 - A wide range of industrial, chemical processing and other areas where flammable gases and vapors may be present
 - Suitability includes use where there may be simultaneous exposure to flammable gases and vapors
- Typical applications include:
 - Power plants
 - Processing plants
 - Chemical plants
 - Oil refineries
 - Waste and sewage treatment
 - Other areas where water and dirt are a problem

Features

- Extends motion sensor coverage around obstacles for Emerson's Connected lighting ecosystem
- Intrinsically safe WirelessHART® Motion Sensor
 - Passive Infrared Motion Sensing with field replaceable PIR Fresnel lens
 - Embedded illuminance sensor
 - Device health monitoring and alerts
- SmartPower™ module (sold separately) provides up to 5 year maintenance-free operation and field replacement without transmitter removal
- Commission within Emerson Plantweb Insight's Connected Lighting Application
 - Asset Management
 - Map Based Commissioning
 - Motion sensor interacts with central control modes
- Field setup with either Emerson AMS Device Manager or Emerson TREX handheld
- Mounting bracket (sold separately) eases installation without the cost of wiring
- Design is suited for detection distances up to 5 m (20 ft).
- Internal antenna design
- Ambient Temperature (standard product): -40 °C to +65 °C (-40 °F to +149 °F)

Warranty

- 5 year standard warranty.

Standard Materials

- Housing: Valox and polycarbonate
- Lens: HDPE
- Gaskets: silicone and polyurethane foam

NEC/CEC Certifications and Compliances

- UL Standard: UL 913; UL 60079-0; UL 60079-11; UL 50e
- CSA Standard: C22.2 No. 0 - 10; C22.2 No. 94.2 - 15; C22.2 No. 60529; C22.2 No. 60079-0:19; C22.2 No. 60079-11:18
- NEMA ANSI/IEC Standards: 60529
- cCSAus: 164460, Certificate Number: 80048037



WMS

ATEX/IECEX Certifications and Compliances

- Certification Type: Wireless Motion Sensor
 - Gas: Zones 0
 - Conforming to ATEX 2014/34/EU: II 1 G
 - Type of Protection: Ex ia IIC T* Ga
 - Temperature Class: T5 to T4
- Ambient Temperature: -40 °C up to +65 °C (-40 °F up to +149 °F)
- ATEX Certificate: INERIS 21ATEX0005X
- IECEX Certificate: IECEX INE 21.0008X
- Index of Protection according EN/IEC 60529: IP66

Related Products

- Mercmaster Connect LED Luminaires
- Industrial Mercmaster Connect LED Luminaires
- Emerson Plantweb Insight Connected Lighting Application
- Emerson 1410S WirelessHART Gateway
- Emerson 1410D WirelessHART Gateway

☛ For warranty details go to www.appleton.emerson.com.

Wireless Motion Sensor

Plantweb Insight™ Connected Lighting Application
Compatible with Mercmaster™ Connect LED Luminaires

NEC/CEC: Class I, Division 1, Groups A, B, C, D | Class I, Zone 0 AEx ia IIC | Ex ia IIC | Type 3R, 4, 4X | IP66 | Suitable for Use in Wet Locations
ATEX/IECEX: Zone 0

Illustrated Features

Passive Infrared Motion Detection



Utilizing passive infrared detection (PIR), the Appleton Wireless Motion Sensor can detect human sized objects from up to 20 ft away. Install the wireless motion sensor in locations where connected lighting motion sensors are obstructed.

Illuminance Sensor

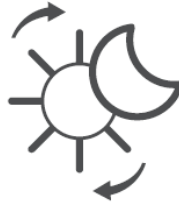

Measures the average light level in lux.

Ambient Temperature Sensing



Monitor the ambient temperature in the installed location.

Plantweb Insight Connected Lighting Application



v

Enables critical system monitoring without adding another lighting control system. The Appleton Wireless Motion Sensor provides auxiliary motion sensor coverage in a connected lighting installation to ensure no operators are left in the dark

Field Replaceable Battery



SmartPower™ module provides up to 5 year maintenance-free operation and field replacement without transmitter removal

Robust and Reliable WirelessHART Protocol

WirelessHART

WirelessHART combines HART technology with wireless capabilities to create an adaptable wireless communications protocol for process automation applications. WirelessHART offers simple installation and robust, layered security to ensure network protection.

⌘ HART and WirelessHART are registered trademarks of the FieldComm Group.

■ SmartPower is a registered trademark of Rosemount Inc.

Note: For other lighting combinations, contact your local Appleton Sales Representative for more information.



Wireless Motion Sensor

Plantweb Insight™ Connected Lighting Application
Compatible with Mercmaster™ Connect LED Luminaires

NEC/CEC: Class I, Division 1, Groups A, B, C, D | Class I, Zone 0 AEx ia IIC | Ex ia IIC | Type 3R, 4, 4X | IP66 | Suitable for Use in Wet Locations
ATEX/IECEX: Zone 0

	Length m (ft)	Weight in kg (lb)	Catalog Number
	Wireless Motion Sensor	0.46 (1.01)	WMS1PT

Accessories and Replacement Parts

	Rosemount™ Mounting Bracket for Rosemount 248	0.58 (1.29)	00249-2612-0001
	Emerson 701P SmartPower™ Module Replacement Battery	0.15 (0.34)	701PGNKF

Dimensions in Millimeters (Inches)

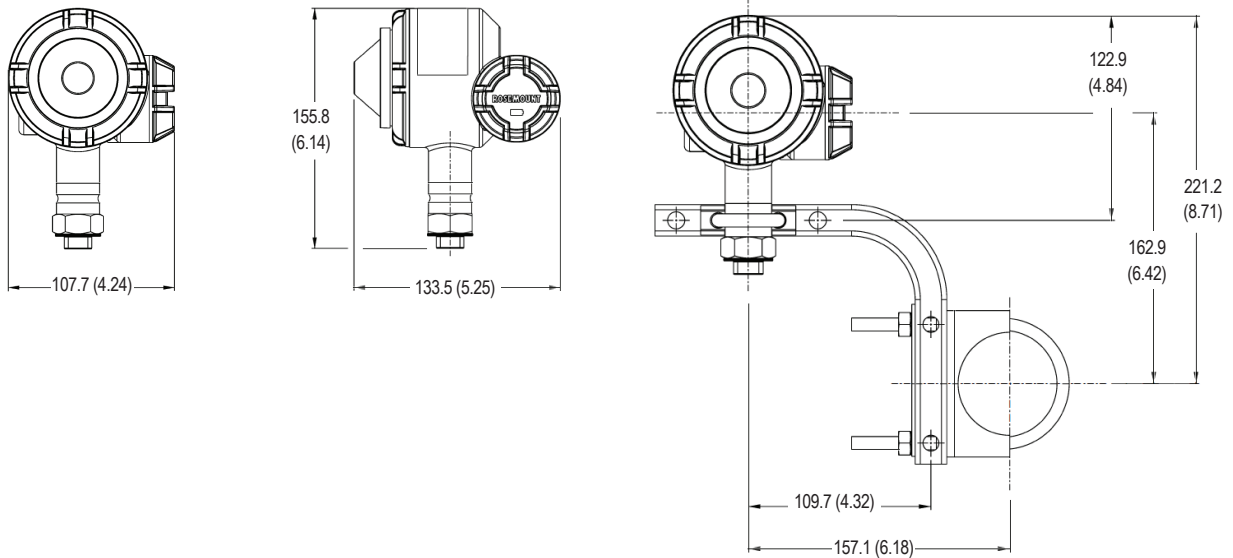

SmartPower and Rosemount are registered trademarks of Rosemount Inc.